

# Up-Flo Filter® Extended Maintenance Cartridge Operation and Maintenance Manual

October 2019  
Rev. A

## Contents

Overview and Product Description.....	3
Operation.....	4
Introduction.....	4
Pollutant Capture.....	4
Best Practices.....	4
Damage Due to Lack of Maintenance.....	4
Inspection & Maintenance.....	4
Overview.....	4
Inspection and Maintenance.....	5
Routine Inspection.....	5
Routine Inspection Procedures.....	5
Routine Maintenance.....	5
Maintenance Scheduling.....	6
Recommended Equipment.....	6
Surface Maintenance Procedure.....	6
Filter Cartridge Replacement.....	7
Up-Flo® Filter Installation Log.....	8
Up-Flo® Filter Inspection Log.....	9
Up-Flo® Filter Maintenance Log.....	11

## Overview and Product Description

The Up-Flo® Filter is a modular high-rate stormwater filtration device designed to capture trash, oil, sediment and remove fine pollutants such as particulate metals and nutrients from stormwater runoff. Designed with efficiency, longevity and upkeep in mind, this high performance, low maintenance filter option that offers higher loading rates and longer membrane life for higher quality stormwater for longer periods between servicing. In general, a minimum of two inspections are required per year to monitor sediment and gross pollutant accumulations. In order to achieve an annual TSS removal rate of 80% for the Up-Flo® Filter, the minimum maintenance frequency specified in the maintenance section for replacement of the filter inserts and removal of accumulated sediment from the sump is mandatory.

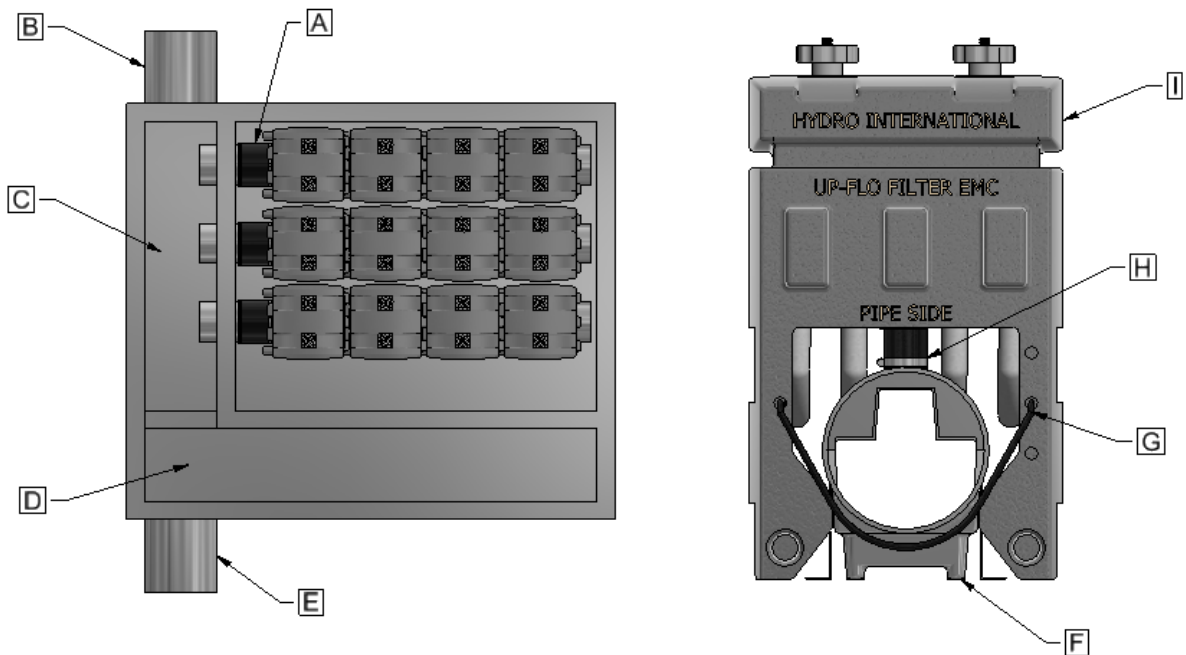

System Components			
A.	Underdrain Coupling	F.	Underdrain
B.	Outlet Pipe	G.	Cartridge Restraining Cord
C.	Outlet Bay	H.	Cartridge Connection Boot
D.	Inlet Bay	I.	Filter Cartridge
E.	Inlet Pipe		

Figure 1: The Up-Flo® Filter EMC

---

## Operation

### Introduction

The Up-Flo® Filter operates on simple fluid hydraulics. It is self-activating, has no moving parts, no external power requirements and is fabricated with durable non-corrosive components. Personnel are not required to operate the unit and maintenance is limited to periodic inspections, sediment and floatables removal and cartridge replacement.

### Pollutant Capture

The Up-Flo® Filter is designed to operate as a “treatment train” by incorporating multiple treatment technologies into a single device. Trash and gross debris are removed by sedimentation and screening before they are introduced to the filtration membranes, delaying surface blinding. The Up-Flo® Filter is a wet-sump device. Between storm events, oil and floatables are stored on the water surface separate from the sediment storage volume in the sump.

### Best Practices

Good housekeeping upstream of the Up-Flo® Filter can significantly extend maintenance interval. For example, sweeping paved surfaces, collecting leaves and grass trimmings, and protecting bare ground from erosion will reduce loading to the system. The filter cartridges should not be installed until construction activities are complete and site stabilization is effective.

### Damage Due to Lack of Maintenance

Delayed maintenance would result in clogged filters. In that situation, an Up-Flo® Filter could go into bypass and there would be no treatment of the incoming stormwater. Replacement of the filter cartridges and removal of sediment from the sump would restore the Up-Flo® Filter to its original treatment efficiency. Establishing and adhering to a regular maintenance schedule ensures optimal performance of the system.

## Inspection & Maintenance

### Overview

The Up-Flo® Filter protects the environment by removing a wide range of pollutants from stormwater runoff. Periodic removal of these captured pollutants is essential to the proper functioning of the Up-Flo® Filter.

Replacement of filter cartridges must be performed inside the vessel. A vactor truck is required for removal of oils, water, sediment, and to completely pump out the vessel to allow for maintenance inside. If you are not using Hydro International or a trained service provider, you must follow OSHA (or other regional) Confined Space Entry procedures when entering the Up-Flo® vessel.

**The minimum required frequency for replacement of the filter cartridges is annually**, whereas the minimum required frequency for removal of accumulated sediment from the sump is dependent on the Up-Flo® Filter configuration. Configurations with a larger sediment storage volume per module will require less frequent removal of accumulated sediment. Regardless, whenever sediment depth in the sump is found to be greater than 6 inches (15 cm), sediment removal is required.

## Inspection and Maintenance

### Routine Inspection

Inspection is a simple process that requires monitoring pollutant accumulations. Maintenance crews should be familiar with the Up-Flo® Filter and its components prior to inspection.

**The following instructions are intended for non-Hydro maintenance service providers and/or those intending to maintain their own Up-Flo® Filter:**

### Routine Inspection Procedures

1. Set up any necessary safety equipment (such as traffic cones) to provide access to the Up-Flo® Filter. Safety equipment should notify passing pedestrian and road traffic that work is being done.
2. Remove the grate or lid to the manhole or vault.
3. Without entering the vessel, look down into the chamber to inspect the inside and to make note of any irregularities.
4. Without entering the vessel, use the pole with the skimmer net to remove floatables and loose debris from the chamber.
5. Using a sediment probe such as a Sludge-Judge®, measure the depth of sediment that has collected in the sump of the vessel. Maximum sediment depth is 6 inches (15 cm).
6. On the Maintenance Log provided by Hydro International, record the date, unit location, estimated volume of floatables and gross debris removed, and the depth of sediment measured. Also note any apparent irregularities such as damaged components or a high standing water level.
7. Securely replace the grate or lid.
8. Remove safety equipment.
9. Contact Hydro International to discuss any irregularities noted during inspection.

### Routine Maintenance

The access port located at the top of the manhole or vault provides access to the Up-Flo® vessel for maintenance personnel to enter the vessel and remove and replace filter cartridges. The same access would be used for maintenance personnel working from the surface to vector out sediment, oil, and water (Figure 2). Unless the Up-Flo® Filter has been installed in a very shallow configuration, it is necessary to have personnel with OSHA Confined Space Entry training performing the maintenance that occurs inside the vessel.

Maintenance intervals are determined from monitoring the Up-Flo® Filter during its first year of operation. Depending on the site, some maintenance activities may have to be performed on a more frequent basis than others.

A vector truck is normally required for oil removal, removal of sediment from the sump, and to dewater the vessel for replacement of the filter cartridges. All inspection and maintenance activities would be recorded in an Inspection and Maintenance Log.

The access port located at the top of the manhole provides unobstructed access for a vector hose and/or skimmer pole to be lowered to the base of the sump.



Figure 2: Sediment is removed from the sump with a vactor hose. Confined space entry is not required for this step.

## Maintenance Scheduling

- Call Hydro International to order replacement filter cartridges prior to scheduling maintenance.
- Because filter cartridge replacement requires entry into the Up-Flo® chamber, maintenance events should be scheduled during dry weather.
- Filter cartridge replacement should occur immediately after a contaminated spill in the contributing drainage area.

## Recommended Equipment

- Safety Equipment (traffic cones, etc.)
- Crow bar to remove grate or lid
- Vactor truck (flexible hose preferred)
- Pressure nozzle attachment
- OSHA Confined Space Entry Equipment
- Replacement Up-Flo® Filter Cartridges (available from Hydro International)
- Hydro International Up-Flo® Filter Maintenance Log
- Screwdriver (flat head)

## Surface Maintenance Procedure

1. Set up any necessary safety equipment (such as traffic cones) around the access of the Up-Flo® Filter. Safety equipment should notify passing pedestrian and road traffic that work is being done.
2. Remove the grate or lid to the manhole or vault.
3. Without entering the vessel, look down into the chamber to inspect the inside. Make note of any irregularities.
4. Once all floatables and oil have been removed, drop the vactor hose to the base of the sump. Vactor out the sediment and gross debris from the sump floor.

5. Retract the vacuum hose from the vessel.
6. On the Maintenance Log provided by Hydro International, record the date, unit location, estimated volume of floatables, oils, and gross debris removed, and the depth of sediment measured. Note any apparent irregularities such as damaged components or blockages.
7. Securely replace the grate or lid. Remove safety equipment.
8. Dispose of sediment and gross debris following local regulations.
9. Dispose of oil and sump water at a licensed water treatment facility or following local regulations.
10. Contact Hydro International to discuss any irregularities noted during cleanout.

## Filter Cartridge Replacement

1. Following OSHA or region specific Confined Space Entry procedures, enter the Up-Flo® Filter Chamber.
2. Starting at the end of the filter cartridge row furthest from the Outlet Bay (Figure 1, Item C) remove each Filter Cartridge (Figure 1, Item I) from the Underdrain (Figure 1, Item A) as described below:
  - a. Unfasten Cartridge Restraining Cord (Figure 1, Item G)
  - b. Loosen Cartridge Connection Boot (Figure 1, Item H) using flathead screwdriver
  - c. Remove Filter Cartridge and transfer to surface.
3. Starting at the end of the Underdrain closest to the Outlet Bay, install new Filter Cartridges, supplied by Hydro International.
  - Orient Filter Cartridge with the labeled "Pipe Side" facing away from the Outlet Bay.
  - Tighten Cartridge Connection Boot using flathead screwdriver
  - Fasten Cartridge Restraining Cord
4. Exit the Up-Flo® Filter chamber and securely replace the grate or lid.
5. On the Maintenance Log provided by Hydro International, record the date, unit location, estimated volume of floatables, oil and gross debris removed, and the depth of sediment measured. Note the number of filter cartridges replaced. Note any irregularities such as damaged components or blockages.
6. Remove safety equipment.
7. Return spent filter cartridges to Hydro International for refurbishment.
8. Contact Hydro International to discuss any irregularities noted during annual maintenance.

## Up-Flo<sup>®</sup> Filter Installation Log

<b>SITE REFERENCE NAME OR NUMBER FOR THIS UP-FLO<sup>®</sup> FILTER LOCATION:</b>	
<b>SITE NAME:</b>	
<b>SITE LOCATIONS:</b>	
<b>OWNER:</b>	<b>SITE CONTRACTOR:</b>
<b>CONTACT NAME:</b>	<b>CONTACT NAME:</b>
<b>COMPANY NAME:</b>	<b>COMPANY NAME:</b>
<b>ADDRESS:</b>	<b>ADDRESS:</b>
<b>TELEPHONE:</b>	<b>TELEPHONE:</b>
<b>FAX:</b>	<b>FAX:</b>

INSTALLATION DATE: \_\_\_\_ / \_\_\_\_ / \_\_\_\_

TOTAL NUMBER OF UP-FLO<sup>®</sup> FILTER CARTRIDGES: \_\_\_\_\_



## Up-Flo® Filter Inspection Log

Site Name: \_\_\_\_\_

Location: \_\_\_\_\_

Owner Name: \_\_\_\_\_

Address: \_\_\_\_\_ Phone Number: \_\_\_\_\_

Site Status: \_\_\_\_\_

Date: \_\_\_\_\_ Time: \_\_\_\_\_ Site Conditions\*: \_\_\_\_\_

\*(Stable, Under Construction, Needing Maintenance, etc.)

Inspection Frequency Key: A=annual; M=Monthly; S=after major storms

Inspection Items		Inspection Frequency	Inspected? (Y/N)	Maintenance Needed? (Y/N)	Comments/Description
<b>Debris Removal</b>	Adjacent area free of debris?				
	Inlets and outlets free of debris?				
	Facility (internally) free of debris?				
<b>Vegetation</b>	Surrounding area fully stabilized?				
	Grass mowed?				
<b>Water retention where required</b>	Water holding chamber(s) at normal pool				
	Evidence of erosion?				
<b>Sediment deposition</b>	Filtration chamber free of sediments?				
	Sedimentation sump not more than 50% full?				
<b>Structural components</b>	Any evidence of structural deterioration?				
	Grates in good condition?				
	Spalling or cracking of structural parts?				
	Outlet/overflow spillway				
<b>Other</b>	Noticeable odors?				
	Any evidence of filter(s) clogging?				
	Evidence of flow bypassing facility?				

Inspector Comments: \_\_\_\_\_

Overall Condition of Up-Flo® Filter\*\*: Acceptable / Unacceptable

\*\*Acceptable would mean properly functioning; unacceptable would mean damaged or required further maintenance

If any of the above Inspection Items are checked “Yes” for “Maintenance Needed”, list Maintenance actions and their completion dates below or on the Maintenance Log provided on page 11 of the Up-Flo® Filter Operation & Maintenance Manual:

Maintenance Action Needed	Due Date

The next routine inspection is scheduled for approximately: (date) \_\_\_\_\_

Inspected by: (signature) \_\_\_\_\_

Inspected by: (printed) \_\_\_\_\_

---

## Up-Flo<sup>®</sup> Filter Maintenance Log

Site Name: \_\_\_\_\_

Location: \_\_\_\_\_

Owner Name: \_\_\_\_\_

Address: \_\_\_\_\_ Phone Number: \_\_\_\_\_

Site Status: \_\_\_\_\_

Date: \_\_\_\_\_ Time: \_\_\_\_\_ Site Conditions\*: \_\_\_\_\_  
\*(Stable, Under Construction, Needing Maintenance, etc.)

Estimated volume of oil/floatable trash removed: \_\_\_\_\_

Sediment depth measured in sump prior to removal: \_\_\_\_\_

Number of Filter Cartridges replaced: \_\_\_\_\_

Inspector Comments: \_\_\_\_\_

---

---

Overall Condition of Up-Flo<sup>®</sup> Filter\*\*: Acceptable / Unacceptable

\*\*Acceptable would mean properly functioning; unacceptable would mean damaged or required further maintenance

Maintained by: (signature) \_\_\_\_\_

Maintained by: (printed) \_\_\_\_\_

---