

SCHEMATIC ONLY - NOT FOR CONSTRUCTION

TANGENT INLET MAY ENTER ON ANY SIDE OF THE DOWNSTREAM DEFENDER

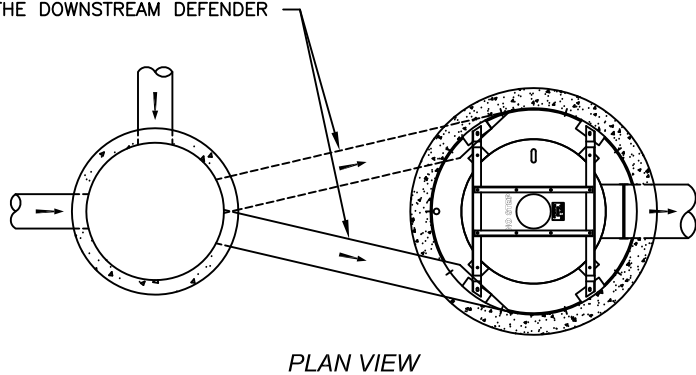

DESIGN NOTES:

- 1) THE OUTLET PIPE INVERT SHOULD BE AT THE SAME ELEVATION OR LOWER THAN INVERTS INTO THE UPSTREAM CHAMBER.
- 2) THE DOWNSTREAM DEFENDER HAS A SUBMERGED INLET PIPE. THE INLET PIPE INVERT IS ONE INLET PIPE DIAMETER BELOW THE OUTLET PIPE INVERT. THE INLET PIPE ENTERS THE UNIT TANGENTIALLY. THE INLET PIPE SLOPE SHOULD NOT EXCEED 15%. HEADLOSS AT PEAK TREATMENT FLOW USES THE MAXIMUM PIPE DIAMETER FOR THAT UNIT. HEADLOSS WILL INCREASE WITH SMALLER INLET PIPES.
- 3) * DISTANCES ARE APPROXIMATE AND DEPEND ON TOP SLAB THICKNESS. ASSUMES A 4" FRAME AND COVER. CONFIRM WITH A HYDRO REPRESENTATIVE.
- 4) ** MAY NOT BE AVAILABLE IN ALL AREAS. CONFIRM WITH A HYDRO REPRESENTATIVE.

MODEL NUMBER & DIAMETER (FT)	PEAK TREATMENT FLOW (CFS)	MAXIMUM PIPE DIAMETER (IN)	HEADLOSS AT PEAK TREATMENT FLOW (IN)	OIL STORAGE CAPACITY (GALLONS)	SEDIMENT STORAGE CAPACITY (CUBIC YARDS)	MIN. DIST. FROM OUTLET INVERT TO TOP OF RIM (FT) *	STANDARD DIST. FROM SUMP FLOOR TO OUTLET INVERT (FT)
4	3.0	12	8	70	0.70	2.8	4.08
6	8.0	18	12	216	2.10	3.24	5.86
8	15.0	24	13	540	4.65	4.2	7.67
10 **	25.0	30	15	1,050	8.70	5.0	9.44
12 **	38.0	36	16	1,770	14.70	5.6	11.18

Notes

REVISION HISTORY

REV	BY	DATE	DESCRIPTION
1	KJM	6/7/12	MIN RIM

Date: 11/1/2011 Scale: NTS

Drawn: EMH Checked: Approved:

Title: DOWNSTREAM DEFENDER®

STORM DRAIN FIT



Stormwater Solutions
 94 Hutchins Drive
 Portland, Maine 04102
 Tel: (207) 756-6200
 Fax: (207) 756-6212
 stormwaterinquiry@hydro-int.com