

PLAN VIEW

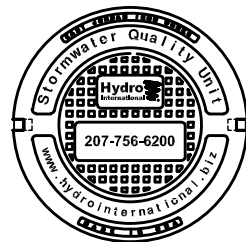

HYDRO FRAME AND COVER (INCLUDED)

GRADE RINGS BY OTHERS AS REQUIRED

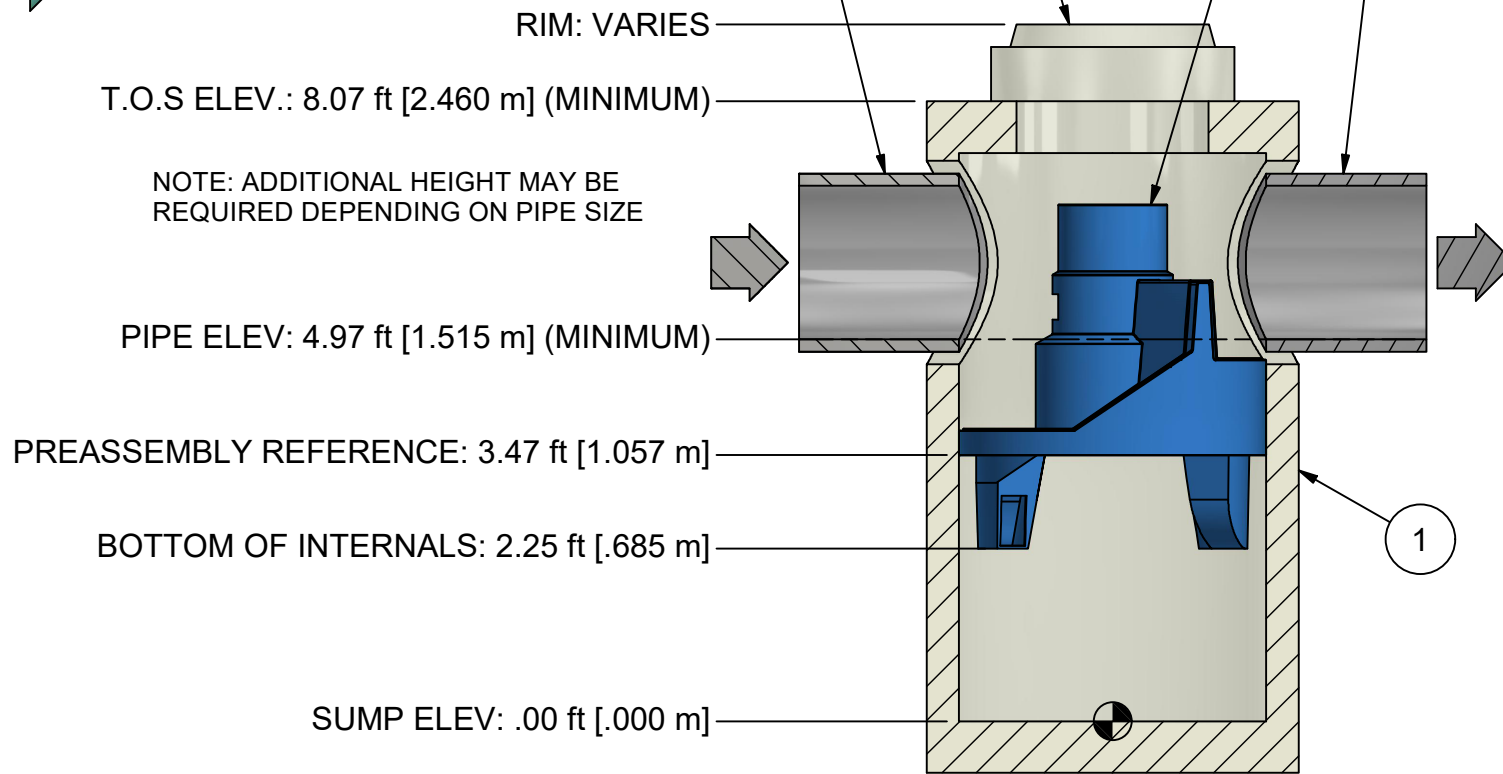

SECTION A-A

RIM: VARIES
 T.O.S ELEV.: 8.07 ft [2.460 m] (MINIMUM)
 NOTE: ADDITIONAL HEIGHT MAY BE REQUIRED DEPENDING ON PIPE SIZE
 PIPE ELEV: 4.97 ft [1.515 m] (MINIMUM)
 PREASSEMBLY REFERENCE: 3.47 ft [1.057 m]
 BOTTOM OF INTERNALS: 2.25 ft [.685 m]
 SUMP ELEV: .00 ft [.000 m]

1. MANHOLE WALL AND SLAB THICKNESSES ARE NOT TO SCALE.
2. CONTACT HYDRO INTERNATIONAL FOR A BOTTOM OF STRUCTURE ELEVATION PRIOR TO SETTING FIRST DEFENSE MANHOLE.
3. CONTRACTOR TO CONFIRM RIM, PIPE INVERTS, PIPE DIA. AND PIPE ORIENTATION PRIOR TO RELEASE OF UNIT TO FABRICATION.

PRODUCT SPECIFICATION:

1. Peak Hydraulic Flow: 18.0 cfs (510 l/s)
2. Min Sediment Storage Capacity: 0.7 cu. yd. (0.5 cu. m.)
3. Maximum Inlet/Outlet Pipe Diameters: 24 in. (600 mm)
4. The Treatment System Shall Use An Induced Vortex To Separate Pollutants From Stormwater Runoff.
5. For More Product Information Including Regulatory Acceptances, Please Visit <https://hydro-int.com/en/products/first-defense>

GENERAL NOTES:

1. General Arrangement drawings only. Contact Hydro International for site specific drawings.
2. The diameter of the inlet and outlet pipes may be no more than 24".
3. Multiple inlet pipes possible (refer to project plan).
4. Inlet/outlet pipe angle can vary to align with drainage network (refer to project plans).
5. Peak flow rate and minimum height limited by available cover and pipe diameter.
6. Larger sediment storage capacity may be provided with a deeper sump depth.

PARTS LIST				
ITEM	QTY	SIZE (in)	SIZE (mm)	DESCRIPTION
1	1	48	1200	I.D. PRECAST MANHOLE
2	1			INTERNAL COMPONENTS (PRE-INSTALLED)
3	1	30	750	FRAME AND COVER (ROUND)
4	1	24 (MAX)	600 (MAX)	OUTLET PIPE (BY OTHERS)
5	1	24 (MAX)	600 (MAX)	INLET PIPE (BY OTHERS)

PROJECTION

IF IN DOUBT ASK

DATE: 11/2/2021 SCALE: 1:30

DRAWN BY: ER CHECKED BY: MRJ APPROVED BY:

Title
 4-ft DIAMETER
 FIRST DEFENSE

GENERAL ARRANGEMENT

Hydro International
 hydro-int.com
 HYDRO INTERNATIONAL

WEIGHT: MATERIAL:

STOCK NUMBER:

DRAWING NO.:
 FD GA-4

SHEET SIZE: B SHEET: 1 OF 1 Rev: -