

PLAN VIEW

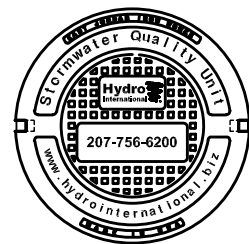

HYDRO FRAME AND COVER (INCLUDED)

GRADE RINGS BY OTHERS AS REQUIRED

T.O.S.: 6.46 ft [1.969 m] (MINIMUM)

NOTE: ADDITIONAL HEIGHT MAY BE REQUIRED DEPENDING ON PIPE SIZE

PIPE INVERTS: 3.71 ft [1.131 m] (MINIMUM)

PREASSEMBLY REFERENCE: 2.67 ft [.813 m]

BOTTOM OF INTERNALS: 1.83 ft [.559 m]

SUMP: .00 ft [.000 m]

RIM: VARIES

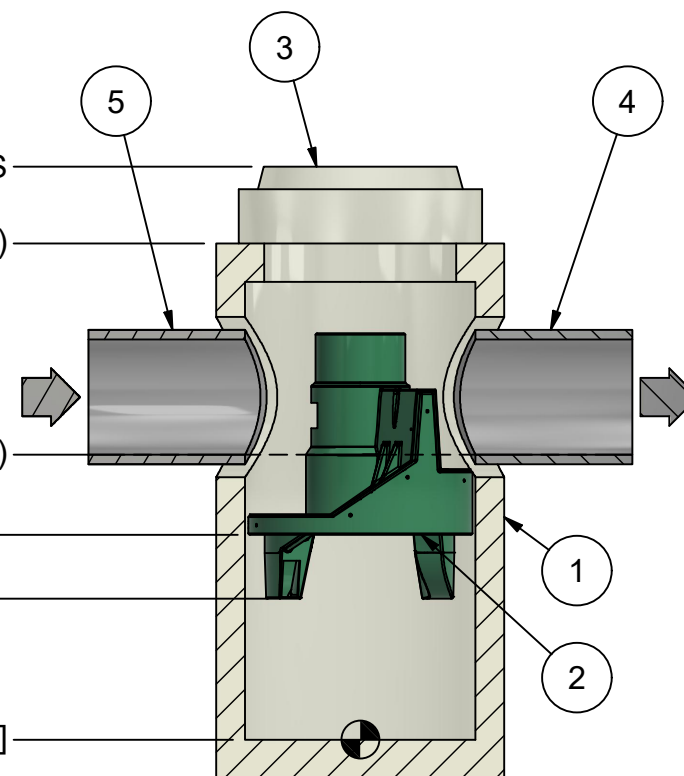

SECTION A-A

1. MANHOLE WALL AND SLAB THICKNESSES ARE NOT TO SCALE.

2. CONTACT HYDRO INTERNATIONAL FOR A BOTTOM OF STRUCTURE ELEVATION PRIOR TO SETTING FIRST DEFENSE MANHOLE.

3. CONTRACTOR TO CONFIRM RIM, PIPE INVERTS, PIPE DIA. AND PIPE ORIENTATION PRIOR TO RELEASE OF UNIT TO FABRICATION.



IF IN DOUBT ASK

DATE: 11/2/2021	SCALE: 1:30	APPROVED BY:
DRAWN BY: ER	CHECKED BY: MRJ	

Title
3-ft DIAMETER
FIRST DEFENSE

GENERAL ARRANGEMENT



hydro-int.com
HYDRO INTERNATIONAL

WEIGHT:	MATERIAL:
---------	-----------

STOCK NUMBER:

DRAWING NO.:
FD GA-3

SHEET SIZE: B	SHEET: 1 OF 1	Rev: -
------------------	------------------	-----------

PRODUCT SPECIFICATION:

1. Peak Hydraulic Flow: 15.0 cfs (424 l/s)
2. Min Sediment Storage Capacity: 0.4 cu. yd. (0.3 cu. m.)
3. Maximum Inlet/Outlet Pipe Diameters: 18 in. (450 mm)
4. The treatment system shall use an induced vortex to separate pollutants from stormwater runoff.
5. For more product information including regulatory acceptances, please visit <https://hydro-int.com/en/products/first-defense>

GENERAL NOTES:

1. General Arrangement drawings only. Contact Hydro International for site specific drawings.
2. The diameter of the inlet and outlet pipes may be no more than 18".
3. Multiple inlet pipes possible (refer to project plan).
4. Inlet/outlet pipe angle can vary to align with drainage network (refer to project plans).
5. Peak flow rate and minimum height limited by available cover and pipe diameter.
6. Larger sediment storage capacity may be provided with a deeper sump depth.

PARTS LIST

ITEM	QTY	SIZE (in)	SIZE (mm)	DESCRIPTION
1	1	36	900	I.D. PRECAST MANHOLE
2	1			INTERNAL COMPONENTS (PRE-INSTALLED)
3	1	30	750	FRAME AND COVER (ROUND)
4	1	18 (MAX)	450 (MAX)	OUTLET PIPE (BY OTHERS)
5	1	18 (MAX)	450 (MAX)	INLET PIPE (BY OTHERS)