

Operation and Maintenance Manual

Hydro-Shield™ Advance

Hydrodynamic Separator for Stormwater Treatment

Table of Contents

3	Hydro-Shield™ Advance by Hydro International
	- Introduction
	- Operation
	- Pollutant Capture and Retention
4	Model Sizes and Configuration
	- Hydro-Shield™ Advance Components
5	Maintenance
	- Overview
	- Maintenance Equipment Considerations
	- Determining Your Maintenance Schedule
6	Maintenance Procedures
	- Inspection
	- Floatables and Sediment Clean Out
8	Hydro-Shield™ Advance Installation Log
9	Hydro-Shield™ Advance Inspection and Maintenance Log

COPYRIGHT STATEMENT: The contents of this manual, including the graphics contained herein, are intended for the use of the recipient to whom the document and all associated information are directed. Hydro International plc owns the copyright of this document, which is supplied in confidence. It must not be used for any purpose other than that for which it is supplied and must not be reproduced, in whole or in part stored in a retrieval system or transmitted in any form or by any means without prior permission in writing from Hydro International plc. Hydro-Shield™ Advance is a trademarked hydrodynamic vortex separation device of Hydro International plc. A patent covering the Hydro-Shield™ Advance has been granted.

DISCLAIMER: Information and data contained in this manual is exclusively for the purpose of assisting in the operation and maintenance of Hydro International plc's First Defense®. No warranty is given nor can liability be accepted for use of this information for any other purpose. Hydro International plc has a policy of continuous product development and reserves the right to amend specifications without notice.

I. Hydro-Shield™ Advance by Hydro International

Introduction

The Hydro-Shield™ Advance leads a new generation of hydrodynamic separator for stormwater treatment that utilize lamella technology for optimal settling performance. It efficiently removes total suspended solids (TSS), trash and hydrocarbons from stormwater runoff without washing out previously captured pollutants while providing an internal peak flow bypass. The Hydro-Shield™ Advance is available in multiple model configurations to accommodate a wide range of pipe sizes, peak flows and depth constraints.

Operation

The Hydro-Shield™ Advance operates on simple fluid hydraulics combined with a lamella treatment module for increased efficiency. It is self-activating, has no moving parts, no external power requirement and is fabricated with durable non-corrosive components. No manual procedures are required to operate the unit and maintenance is limited to monitoring accumulations of stored pollutants and periodic clean-outs. The Hydro-Shield™ Advance has been designed to allow for easy and safe access for inspection, monitoring and clean-out procedures. Neither entry into the unit nor removal of the internal components is necessary for maintenance, thus safety concerns related to confined-space-entry are avoided.

Pollutant Capture and Retention

The internal components of the Hydro-Shield™ Advance have been designed to optimize pollutant capture. Sediment is captured and retained in the base of the unit (Fig.1).

The pollutant storage volumes are isolated from the built-in bypass chamber to prevent washout during high-flow storm events. The sump of the Hydro-Shield™ Advance retains a standing water level between storm events. This ensures a quiescent flow regime at the onset of a storm, preventing resuspension and washout of pollutants captured during previous events.

Applications

- Stormwater treatment at the point of entry into the drainage line
- Sites constrained by space, topography or drainage profiles with limited slope and depth of cover
- Retrofit installations where stormwater treatment is placed on or tied into an existing storm drain line
- Pretreatment for filters, infiltration and storage

Advantages

- Integral bypass conveys large peak flows without the need for “offline” arrangements using separate junction manholes
- Advanced Treatment module for effective sediment capture
- Easy installation and maintenance
- Accommodates large pipe diameters

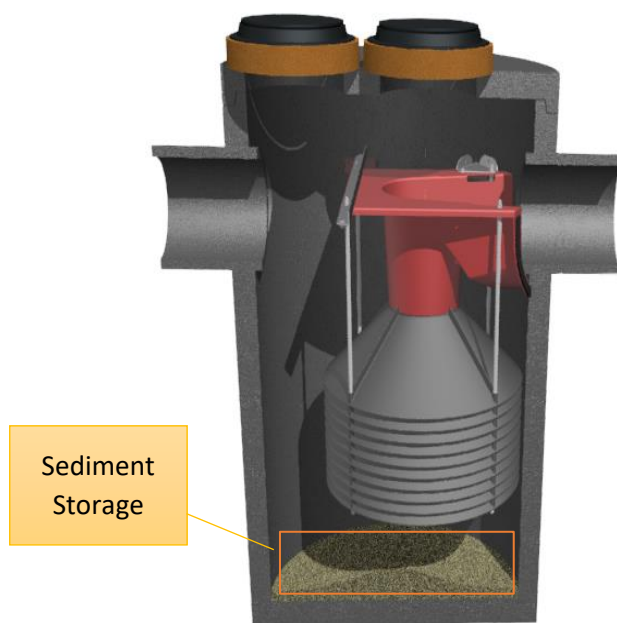

Figure 1: Pollutant storage volume in the Hydro-Shield™ Advance

II. Model Sizes & Configurations

The Hydro-Shield™ Advance inlet and internal bypass arrangements are available in several model sizes and configurations. All Hydro-Shield™ Advance models include the internal components that are designed to remove and retain total suspended solids (TSS), (Fig.2). Hydro-Shield™ Advance model sizes (diameter) are shown in Table 1.

III. Maintenance

Hydro-Shield™ Advance Components

1. **Inlet Pipe**
2. **Treatment Module**
3. **Outlet Module**
4. **Outlet Pipe**
5. **Internal Bypass**
6. **Sediment Storage**
7. **Cover(s)**

Hydro-Shield™ Advance Model Sizes (MH Dia.)
HSA-4ft
HSA-6ft
HSA-8ft

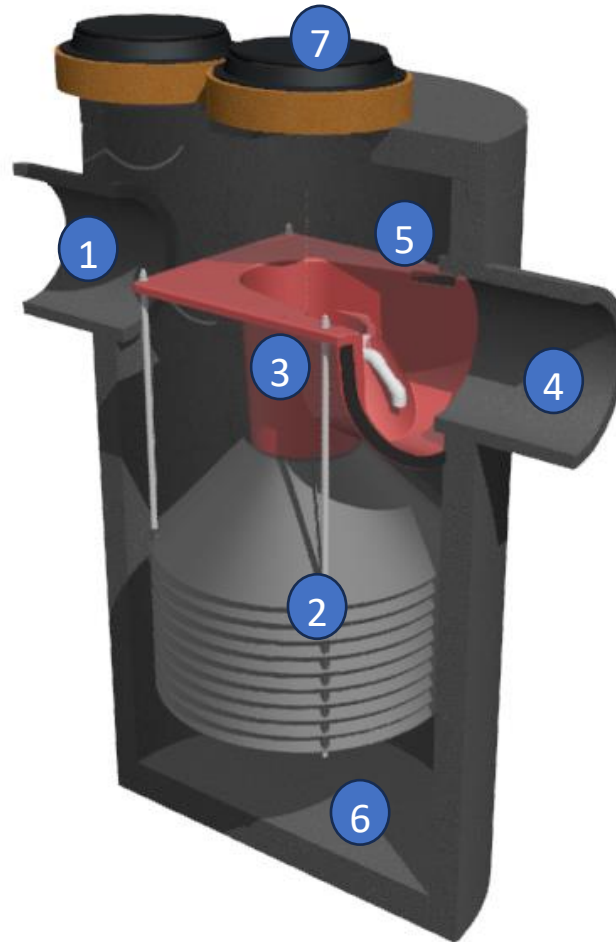

Overview

The Hydro-Shield™ Advance protects the environment by removing a wide range of pollutants from stormwater runoff. Periodic removal of these captured pollutants is essential to the continuous, long-term functioning of the Hydro-Shield™ Advance. The unit will efficiently capture and retain sediment until the stated sediment storage capacity has been reached. The Hydro-Shield™ Advance will continue to operate afterwards but prolonged operation will reduce removal efficiency and may cause damage to the equipment.

The Hydro-Shield™ Advance allows for easy and safe inspection, monitoring and clean-out procedures. A commercially or municipally owned sump-vac is used to remove the captured sediment. Access ports are located in the top of the manhole. Maintenance events may include inspection, floatables removal, or sediment removal. Maintenance events do not require entry into the manhole, nor do they require the internal components of the Hydro-Shield™ Advance to be removed. In the case of inspection and floatables removal, a vactor truck is not required. However, a vactor truck is required if the maintenance event is to include sediment removal.

Maintenance Equipment Considerations

The internal components of the Hydro-Shield™ Advance have a dedicated area on the perimeter through which the sediment storage sump can be accessed with a sump vac hose. Access to the Outlet Module is also provided. (Fig.3). On 4ft units, access is via a shared manhole cover. Larger units are provided with 2 separate covers.

Determining Your Maintenance Schedule

The frequency of clean-out is determined in the field after installation. During the first year of operation, the unit should be inspected every six months to determine the rate of sediment and floatables accumulation. A simple probe such as a Sludge-Judge® can be used to determine the level of accumulated solids stored in the sump. This information can be recorded in the maintenance log (see page 9) to establish a routine maintenance schedule.

The vactor procedure, including both sediment and floatables removal, for Hydro-Shield™ Advance typically takes less than 30 minutes

Fig.3 Hydro-Shield™ Advance maintenance access.

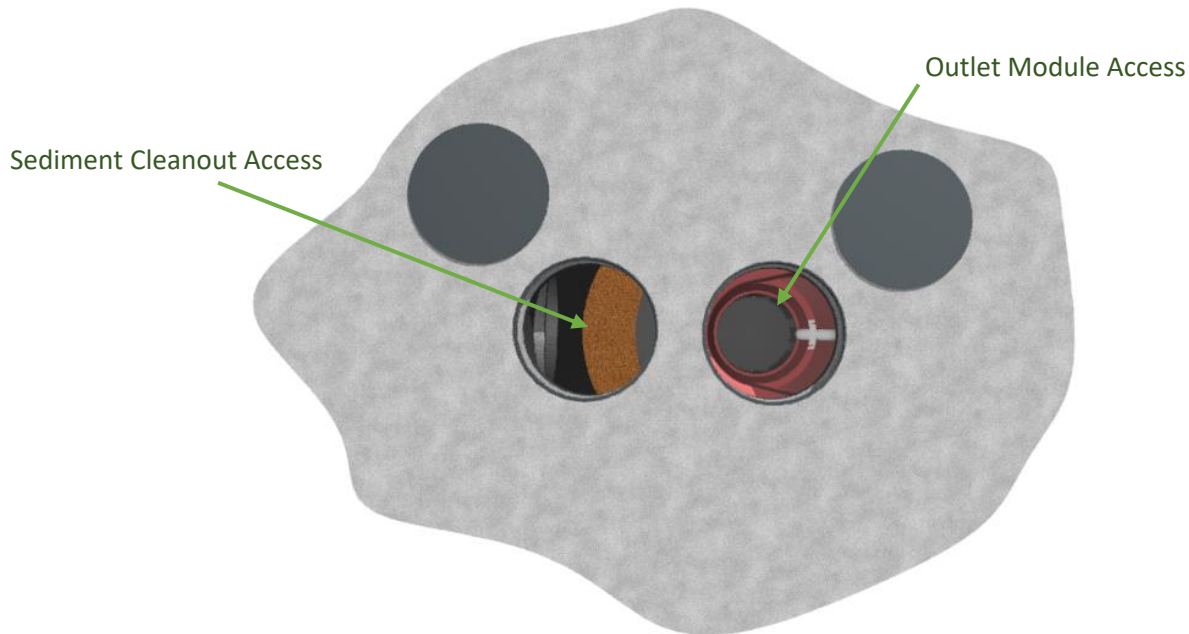

Inspection Procedures

1. Set up any necessary safety equipment around the access port or grate of the Hydro-Shield™ Advance as stipulated by local ordinances. Safety equipment should notify passing pedestrian and road traffic that work is being done.
2. Remove the manhole lid(s).
3. Without entering the vessel, look down into the chamber to inspect the inside. Make note of any irregularities. Fig.4 shows the standing water level that should be observed.
4. Without entering the vessel, use the pole with the skimmer net to remove floatables and loose debris from the components and water surface.
5. Using a sediment probe such as a Sludge Judge®, measure the depth of sediment that has collected in the sump of the vessel.
6. On the Maintenance Log (see page 9), record the date, unit location, estimated volume of floatables and gross debris removed, and the depth of sediment measured. Also note any apparent irregularities such as damaged components or blockages.
7. Securely replace the grate or lid.
8. Take down safety equipment.
9. Notify Hydro International of any irregularities noted during inspection

Floatables and Sediment Clean Out

Floatables clean out is typically done in conjunction with sediment removal.

A commercially or municipally owned sump-vac is used to remove captured sediment and floatables (Fig.4).

Floatables and loose debris can also be netted with a skimmer and pole.

The access port located at the top of the manhole provides unobstructed access for a vactor hose to be lowered to the base of the sump.

Scheduling

- Floatables and sump clean out are typically conducted once a year during any season.
- Floatables and sump clean out should occur as soon as possible following a spill in the contributing drainage area.

Recommended Equipment

- Safety Equipment (traffic cones, etc)
- Crow bar or other tool to remove grate or lid
- Pole with skimmer or net (if only floatables are being removed)
- Sediment probe (such as a Sludge Judge®)
- Vactor truck (flexible hose recommended)
 - Spray hose or wand and clean water
- Hydro-Shield™ Advance Maintenance Log

Fig.4 Floatables are removed with a vactor hose



Procedures Floatables and Sediment Clean Out Procedures

1. Set up any necessary safety equipment around the access port or grate of the Hydro-Shield™ Advance as stipulated by local ordinances. Safety equipment should notify passing pedestrian and road traffic that work is being done.
2. Remove the lid(s) to the manhole.
3. Without entering the vessel, look down into the chamber to inspect the inside. Make note of any irregularities.
4. Remove floatables stored on the surface of the water with the vactor hose or with the skimmer or net
5. Using a sediment probe such as a Sludge Judge®, measure the depth of sediment that has collected in the sump of the vessel and record it in the Maintenance Log (page 9).
6. Once all floatables have been removed, drop the vactor hose to the base of the sump. Vactor out the sediment and gross debris off the sump floor
7. Once the water level is below the Treatment Module, visually inspect the Outlet Module and inside of the Treatment Module
8. If necessary, use a spray hose or wand to dislodge any debris or silt and flush them into the sump.
9. Retract the vactor hose from the vessel.
10. On the Maintenance Log provided by Hydro International, record the date, unit location, estimated volume of floatables and gross debris removed, and the depth of sediment measured. Also note any apparent irregularities such as damaged components, blockages, or irregularly high or low water levels.
11. Securely replace the lid(s).

Maintenance at a Glance

- Regularly during first year of installation
- Every 6 months after the first year of installation
- Once per year, with sediment removal
- Following a spill in the drainage area
- Once per year or as needed
- Following a spill in the drainage area

Inspection

Floatables Removal

Sediment Removal

NOTE: For most clean outs the entire volume of liquid does not need to be removed from the manhole. Only remove the first few inches of oils and floatables from the water surface to reduce the total volume of liquid removed during a clean out

Hydro-Shield™ Advance Installation Log

HYDRO INTERNATIONAL REFERENCE NUMBER:	
SITE NAME:	
SITE LOCATION:	
OWNER:	CONTRACTOR:
CONTACT NAME:	CONTACT NAME:
COMPANY NAME:	COMPANY NAME:
ADDRESS:	ADDRESS:
TELEPHONE:	TELEPHONE:
FAX:	FAX:

INSTALLATION DATE: / /

MODEL SIZE (CIRCLE ONE):

INLET :

Hydro-Shield™ Advance Inspection and Maintenance Log

Date	Initials	Depth of Floatables and Oils	Sediment Depth Measured	Volume of Sediment Removed	Site Activity and Comments